

Contents

ENGLISH	2
Vehicle Details.....	2
Adapter Kit Details.....	2
Compatible Compressors	3
Compressor Kit Configurations	3
Foreword	4
Standard Fastener Torque Values.....	4
Parts View	5
Parts List	5
Pre Installation	6
Compressor installation.....	6
Drive Belt.....	6
Post Installation	7
Notes	8

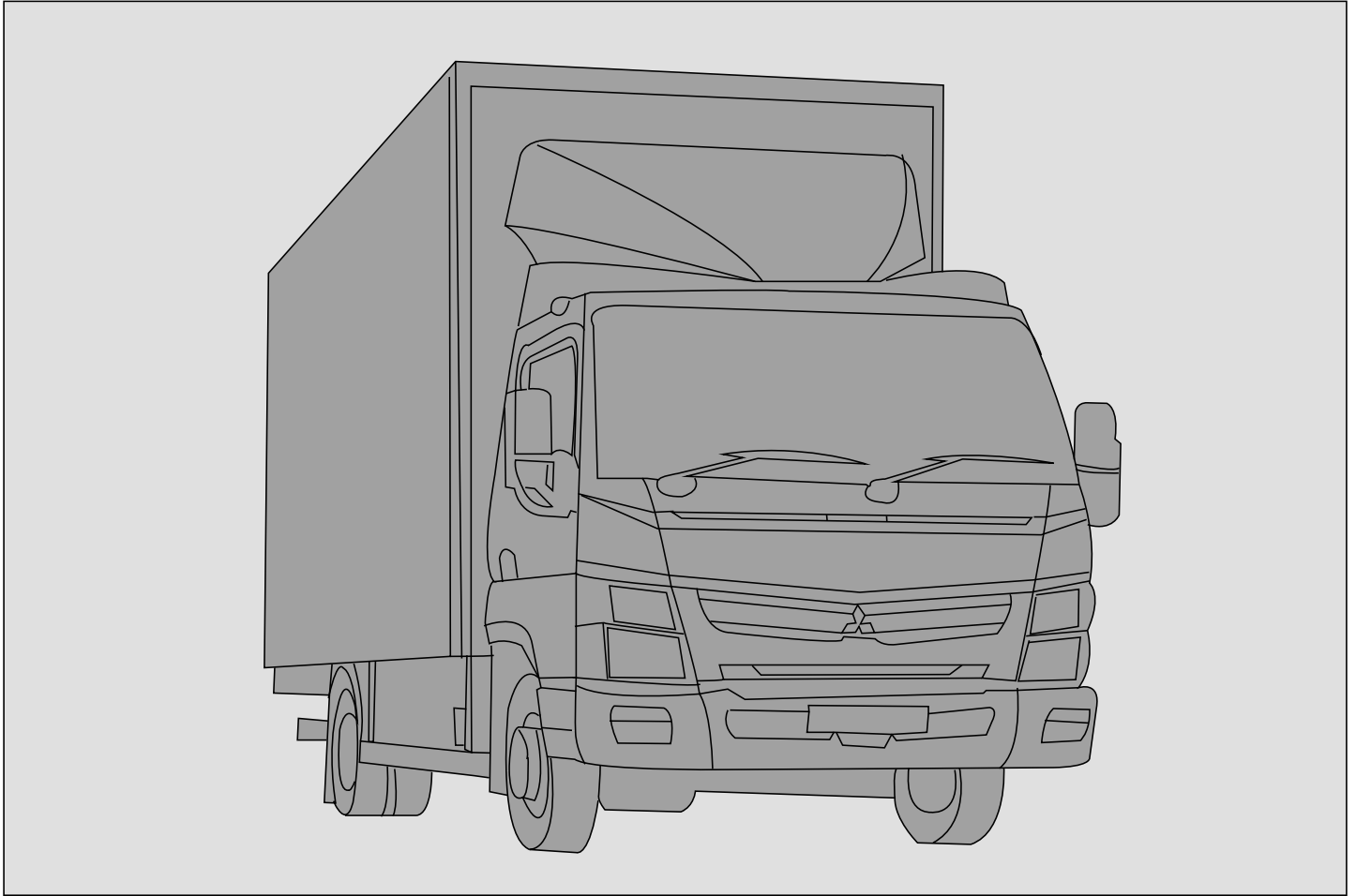

VEHICLE DETAILS

Manufacturer	Mitsubishi Fuso
Make	Canter TF MY2012
Model	7C15, 7C18
Engine CC	2998
Engine Details	Euro 5 4P10-T4, 4P10-T6
Year	2012>
Chassis Nos.	N/A
LHD	YES
RHD	YES
PAS	YES
A/C	NO
Voltage	12v

KIT DETAILS

Kit Part No.	0500.7262
Description	Standard Kit
Compressor RPM	4393 @ Max Engine
	Power Output
Fitting Time	30 Minutes
Suction Fitting	45°
Discharge Fitting	45°
Belt Type	7PK 1605
Belt Part No.	0820.6511

COMPATIBLE COMPRESSORS

SELTEC	-	-	TM21-HS
Comp No	-	-	0381.5322
Seltec No.	-	-	-
Mounting	-	-	Direct
Rotor	-	-	8PV
Armature	-	-	3E
Diameter	-	-	127
Voltage	-	-	12
Orientation	-	-	-
Fitting	-	-	PAD
Manifold	-	-	Bolt

QUE	-	-	QP21-HD
Comp No	-	-	0391.5322
Que No.	-	-	-
Mounting	-	-	Direct
Rotor	-	-	8PV
Armature	-	-	3E
Diameter	-	-	127
Voltage	-	-	12
Orientation	-	-	-
Fitting	-	-	PAD
Manifold	-	-	Bolt

SANDEN	SD5H09	SD5H14	SD7H15
Comp No	-	-	-
Sanden No.	-	-	-
Mounting	-	-	-
Rotor	-	-	-
Armature	-	-	-
Diameter	-	-	-
Voltage	-	-	-
Orientation	-	-	-
Fitting	-	-	-

Notes

COMPRESSOR KIT CONFIGURATIONS

PART NUMBER	COMPRESSOR KIT PART NOS		DESCRIPTION	QTY.
	0521.7042	0591.7042		
0381.5322	●		TM21 Direct Mount 8PV 3E 127 12v PAD Bolt	1
0391.5322		●	QP21 Direct Mount 8PV 3E 127 12v PAD Bolt	1

● = Additional parts to standard kits.

FOREWORD

- The purpose of this manual is to facilitate the installation of a direct drive compressor. The information given is merely instructive, should any complications arise contact the Technical department. The manufacturer's warranty does not cover any problems caused by defective installation or alterations made unless authorised. The manufacturer shall not be responsible for any injury, damage or loss caused directly or indirectly as a result of using this manual or the information contained within it.

1 SAFETY MEASURES:

Before fitting the Compressor adapter drive kit, ensure the following for damage:

- a Inner and outer trim and body work
- b Engine idle pace
- c Check all the vehicle functions

Check list:

- a Ensure that the right kit has been selected
- b Before installing, check that all the correct pieces are present; also ensure that there are no missing or broken pieces
- c When fitting, make sure the vehicle is properly protected against damage.

Installation apparatus

- a Calibrated torque wrench
- b Hand service tools
- c Protective covers and shields

2 PRECAUTIONS

- a Detach the battery negative lead.
- b Torque all bolts where stated using a calibrated torque wrench.
- c Take extreme care with moving parts.
- d Remove the vehicles ignition key and keep it with you.
- e Wear eye safeguards to make sure that liquid refrigerant never touches your skin





Caution: Measures must be followed accurately to steer clear of the possibility of damage to individuals

Warning: This calls awareness to actions which must be pursued to avoid damage to the components.

NB: This calls awareness to make the job easier or gives useful information.

STANDARD FASTENER TORQUE VALUES

- In the absence of specific torque values detailed in this fitting instruction manual, the following chart can be used as a guide to the maximum safe torque for specific size and grade of fastener.

STRENGTH								
	Max Torque		Max Torque		Max Torque		Max Torque	
Dia / Pitch	lb.ft	Nm	lb.ft	Nm	lb.ft	Nm	lb.ft	Nm
M5 x 0.80	2	3	4.5	6	6.5	9	7.5	10
M6 x 1.00	4	5.5	7.5	10	11	15	13	18
M8 x 1.25	10	13	18	25	26	35	33	45
M10 x 1.25	20	27	39	53	57	78	66	90
M10 x 1.50	18	25	37	50	55	73	63	86
M12 x 1.75	33	45	63	85	97	130	111	150
M14 x 2.00	55	75	103	140	151	205	177	240
M16 x 2.00	85	115	159	215	232	315	273	370

PARTS VIEW

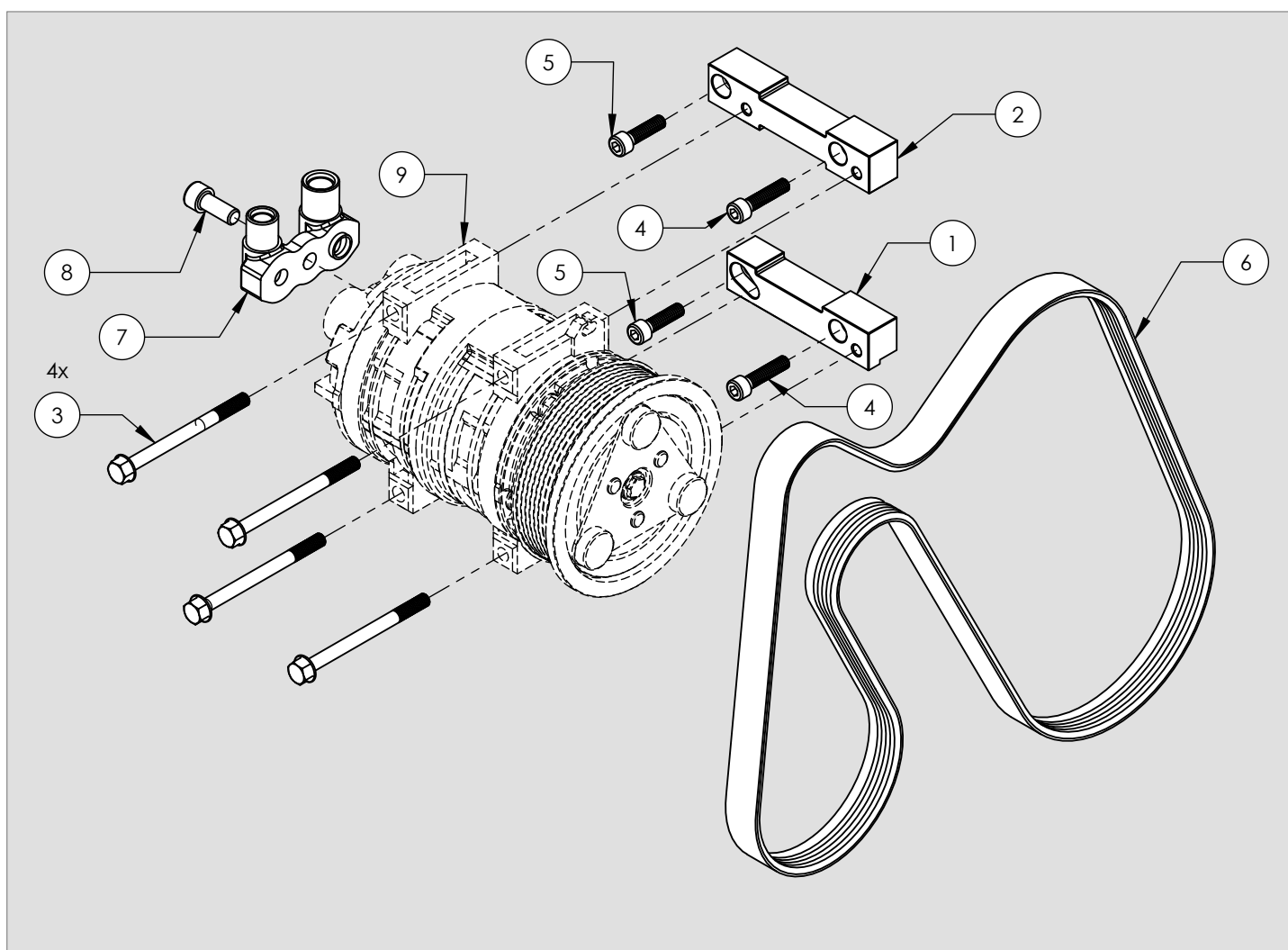

PARTS LIST

ITEM	PART NO.	DESCRIPTION	QTY.	COMMENTS
1	3020.5881	Compressor Mount - A	1	-
2	3020.5891	Compressor Mount - B	1	-
3	2704.5361	Hexagon flange bolt - M8 x 100 : 1.25 - 8.8	4	-
4	2704.5541	Hexagon socket head cap screw M8 x 35 : 1.25 - 12.9	2	-
5	2704.5551	Hexagon socket head cap screw M8 x 30 : 1.25 - 12.9	2	-
6	0820.6511	Belt - 7PK 1605	1	-
7	0425.0501	Manifold V 3/4 x 7/8 Short	1	-
8	2705.5171	Hex socket head cap screw - M10 x 25 : 1.50 - 12.9	1	-
9	0381.5322	TM21 Direct Mount 8PV 3E 127 12v PAD Bolt	1	Not Included
9	0391.5322	QP21 Direct Mount 8PV 3E 127 12v PAD Bolt	1	Not Included

PRE-INSTALLATION

N.B Prior to commencing work, please examine the instructions with care. The alphabetical symbols on the diagram relate to written instructions, numerical symbols relate to the parts listing.

Dismantle the following:

1. Tilt the engine cab by following the manufacturers instructions.
2. Remove the engine under panel 2 x M10 and 4 x M8 Bolts.
3. Using a suitable tool rotate the automatic belt tensioner pulley **(A)** Anti-clockwise - Fig.1
4. Remove the original manufacturers poly groove drive belt **(B)** noting the original routing.

NB : If the belt routing is different from the diagram shown in Fig.1 report your findings to your Kit/System supplier before proceeding.

5. Remove and discard the foolish pulley assembly **(C)** from the mounting bracket **(F)** by removing the 3 x M8 bolts **(D)** - Fig 2
6. Remove and discard the wiring plug securing bracket **(E)** by removing the 2 x M8 bolts - Fig 2
7. Remove the wiring plug from the bracket **(E)** and tie the wiring plug and loom to the alternator loom using the supplied cable tie.

COMPRESSOR INSTALLATION

1. Fasten the manifold **(7)** to the compressor using the M10 x 25 socket head bolt **(8)** - Fig 3
2. Torque bolt **(8)** to 35Nm / 26Lb ft
3. Fit the supplied compressor mountings **(1)** & **(2)** to the original mount bracket **(F)** using the supplied cap screws **(4)** M8 x 35 to the front and **(5)** M8 x 30 to the rear - Fig 3
4. Torque bolts **(4)** & **(5)** to 30Nm / 22Lb ft
5. Fit the compressor **(8)** using the supplied bolts **(3)** M8 x 100 - Fig 3
6. Torque bolts **(3)** to 25Nm / 18Lb ft

DRIVE BELT

1. Fit the supplied replacement poly groove engine drive belt **(6)** to the engine in the same configuration in accordance with the original manufacturers design - Fig.4/5/6

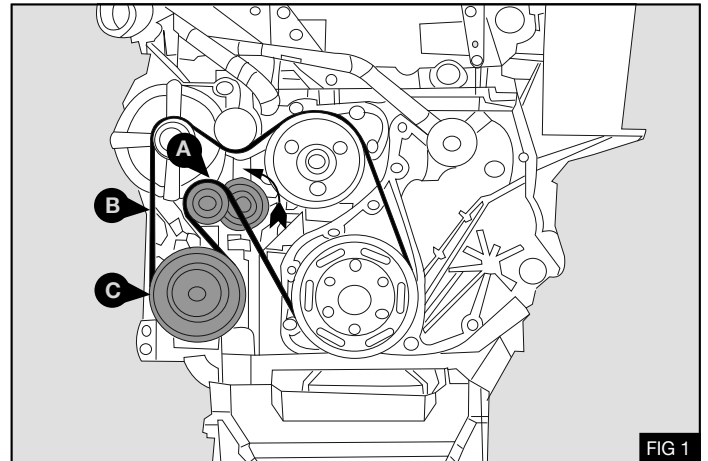

FIG 1

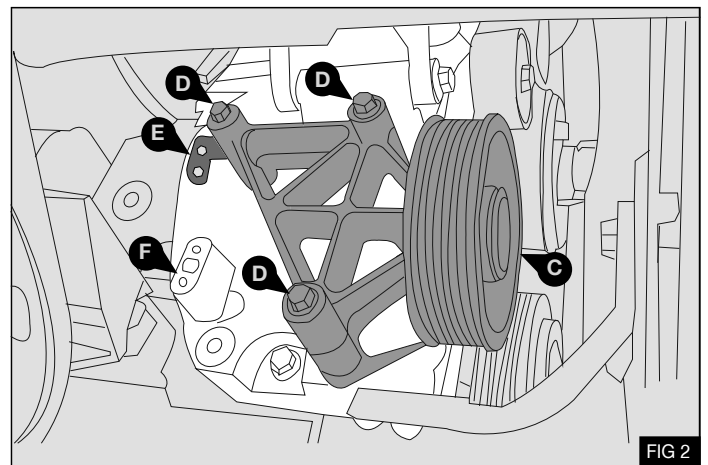

FIG 2

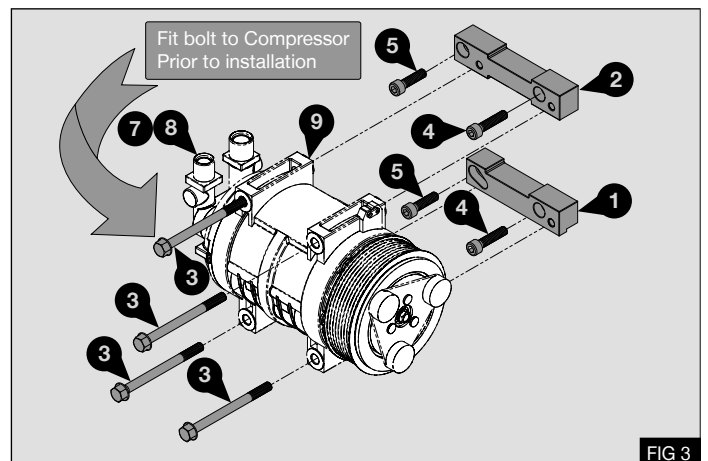

FIG 3

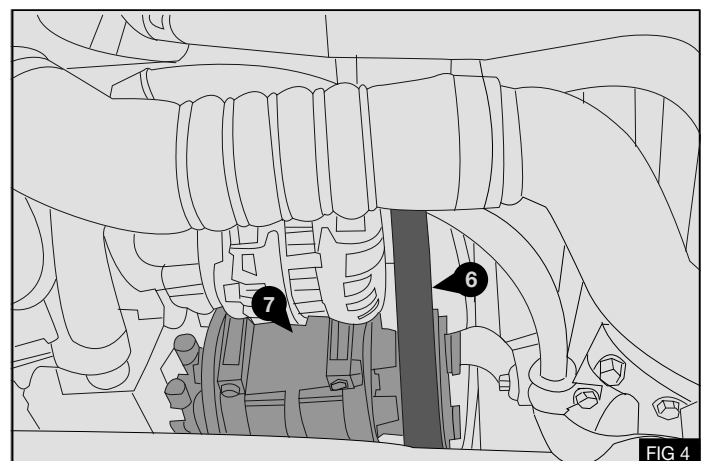

FIG 4

DRIVE BELT - CONTINUED

- CP** Crankshaft Pulley
- AT** Automatic Tensioner
- WP** Water Pump
- AL** Alternator
- IP** Idle Pulley
- RC** Refrigeration Compressor

Warning : Fit the drive belt one groove back from the front of the compressor clutch - Fig 6

POST INSTALLATION

1. Before starting the engine check all the installed parts and ensure that the belt is installed correctly. Run the unit for at least ten minutes, then check the whole mounting assembly and previously removed parts. Attach the supplied warning label on to a suitable location.

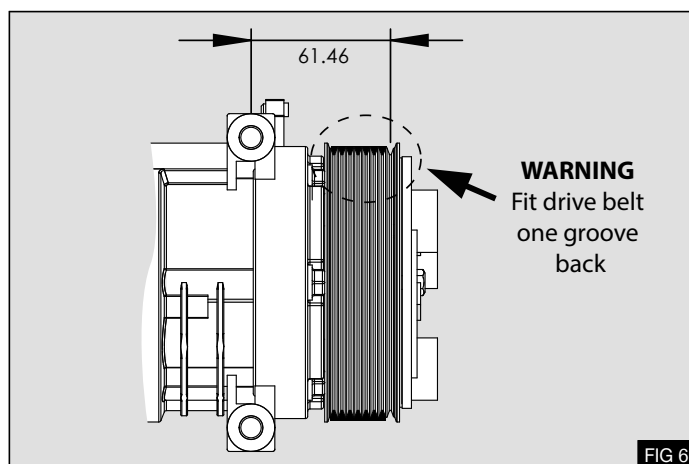
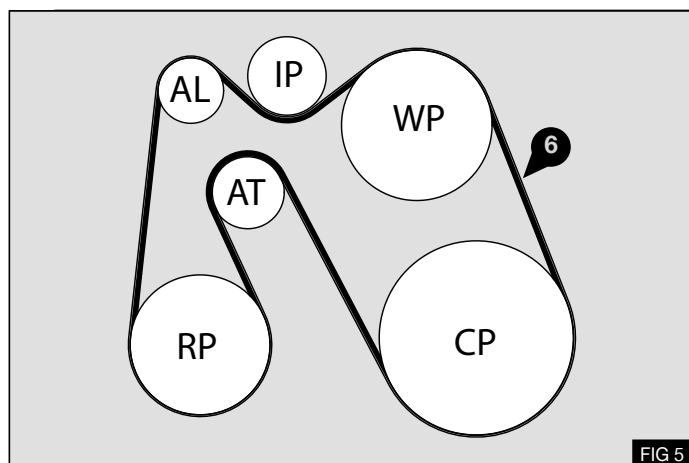

Notes